



Bass Cabinet

Indy
210

Indy
115



MANUALE D'USO

I

OPERATING MANUAL

UK

MODE D'EMPLOI

F

BENUTZER-HANDBUCH

D

Worldwide Distribution
FBT elettronica SpA

Guglielmo Cicognani, Via Mameli n. 53 48018 FAENZA (RA)

Tel. +39 0546 620480

www.cicognaniamps.com

Mail: italia@cicognaniamps.com / export@cicognaniamps.com / support@cicognaniamps.com

Configurazione: bass reflex
 Potenza : 500W RMS (1200W peak)
 Impedenza: 8 Ohm
 Woofers: 2 x 10" B&C al neodimio
 Driver a compressione da 1"
 Struttura in multistrato di betulla
 Connettori SPEAKON In/Out
 Regolatore per controllo livello HF
 Dimensioni (LxHxP) mm 580x500x450
 Peso: 17kg.

Bass reflex design
Power : 500W RMS (1200W peak)
Impedance: 8 Ohm
2 x 10" B&C custom neodymium woofer
1 x 1" HF compression driver
Birch plywood enclosure with tolex finish
Double In/Out SPEAKON connectors
Regulator to control HF level
Dimensions (WxHxD) mm 580x500x450
Weight: 17kg.

Bass reflex configuration
 Puissance : 500W RMS (1200W peak)
 Impédance: 8 Ohm
 2 x 10" B&C woofer custom au néodyme
 1 x 1" HF compression driver
 Structure en boulot à strates multiples
 Double branchement entrée/sortie prise SPEAKON
 Contrôleur de niveau HF
 Dimensions (LxHxP)mm580x500x450
 Poids: 17kg.

Bass reflex Konfiguration
Leistung : 500W RMS (1200W peak)
Impedanz: 8 Ohm
2 x 10" B&C Custom NeodymWoofer
1 x 1" HF Kompressionstreiber
Rahmen aus Birke Multiplex
Doppelter Steckeranschluss Eingang/Ausgang
HF-Einstellung
Abmessungen (LxHxP) mm 580x500x450
Gewicht: 17kg.

Il regolatore (A) controlla il livello di emissione del tweeter e offre all'amplificatore sempre la stessa impedenza indipendentemente dal volume con cui è tenuto l'altoparlante.

The regulator (A) controls the emission level of the tweeter and gives the amplifier still the same impedance independent of the volume at which the speaker is set.

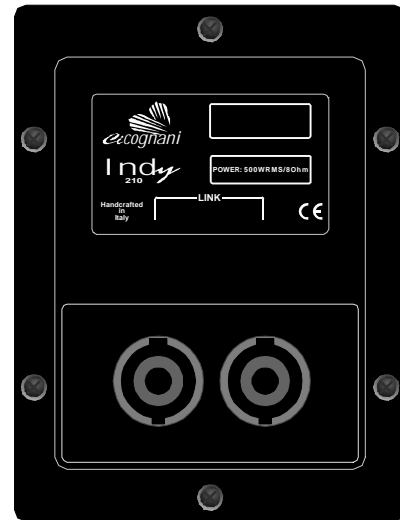
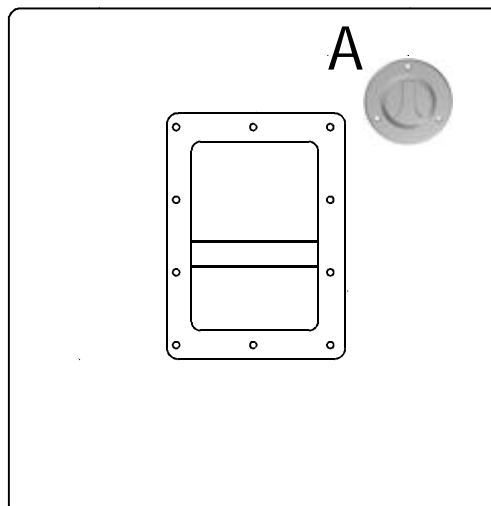

Le prese SPEAKON sono collegate in parallelo; una presa può essere utilizzata per il collegamento della cassa all'uscita di un amplificatore di potenza, l'altra per collegare un secondo box.

The SPEAKON sockets are wired in parallel mode; one socket can be used to connect the loudspeaker to the output of a power amplifier, while the other can be used to connect a second loudspeaker.

Les prises SPEAKON sont branchées en parallèle; une prise peut être utilisée pour le branchement de l'enceinte à la sortie d'un amplificateur de puissance, l'autre pour brancher un second boîtier.

Die SPEAKON -Buchsen sind parallel geschaltet; eine Buchse kann zum Anschluss der Box an den Ausgang eines Leistungsverstärkers, die andere zum Anschluss einer zweiten Box verwendet werden.

Le contrôleur (A) contrôle le niveau d'émission du tweeter et offre toujours à l'amplificateur la même impédance, indépendamment du volume du haut-parleur.

Mittels Reguliervorrichtung (A) wird das Emissionsniveau des Tweeters gesteuert. Gleichzeitig wird dem Verstärker stets dieselbe Impedanz gewährleistet, unabhängig von der Lautstärke der Lautsprecher.

Configurazione: bass reflex
 Potenza : 400W RMS (1200W peak)
 Impedenza: 8 Ohm
 Woofers: 1 x 15" B&C al neodimio
 Driver a compressione da 1"
 Struttura in multistrato di betulla
 Connettori SPEAKON In/Out
 Regolatore per controllo livello HF
 Dimensioni (LxHxP) mm 580x650x450
 Peso: 19,5kg.

Bass reflex design
Power: 400W RMS (1200W peak)
Impedance: 8 Ohm
1 x 15" B&C custom neodymium woofer
1 x 1" HF compression driver
Birch plywood enclosure with tolex finish
Double In/Out SPEAKON connectors
Regulator to control HF level
Dimensions (WxHxD) mm 580x650x450
Weight: 19,5kg.

Bass reflex configuration
 Puissance : 400W RMS (1200W peak)
 Impédance: 8 Ohm
 1 x 15" B&C woofer custom au néodyme
 1 x 1" HF compression driver
 Structure en Boulot à strates multiples
 Double branchement entrée/sortie prise SPEAKON
 Contrôleur de niveau HF
 Dimensions (LxHxP) mm 580x650x450
 Poids: 19,5kg.

Bass reflex Konfiguration
Leistung: 400W RMS (1200W peak)
Impedanz: 8 Ohm
1 x 15" B&C Custom Neodym Woofer
1 x 1" HF Kompressionstreiber
Rahmen aus Birke Multiplex
Doppelter Steckeranschluss Eingang/Ausgang
HF-Einstellung
Abmessungen (LxHxP) mm 580x650x450
Gewicht: 19,5kg.

Il regolatore (A) controlla il livello di emissione del tweeter e offre all'amplificatore sempre la stessa impedenza indipendentemente dal volume con cui è tenuto l'altoparlante.

The regulator (A) controls the emission level of the tweeter and gives the amplifier still the same impedance independent of the volume at which the speaker is set.

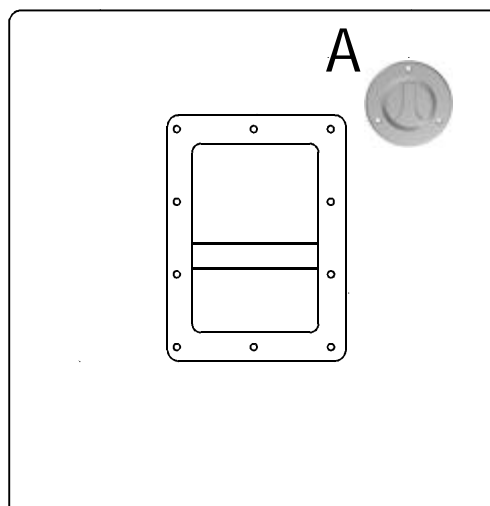

Le contrôleur (A) contrôle le niveau d'émission du tweeter et offre toujours à l'amplificateur la même impédance, indépendamment du volume du haut-parleur.

Mittels Reguliervorrichtung (A) wird das Emissionsniveau des Tweeters gesteuert. Gleichzeitig wird dem Verstärker stets dieselbe Impedanz gewährleistet, unabhängig von der Lautstärke der Lautsprecher.

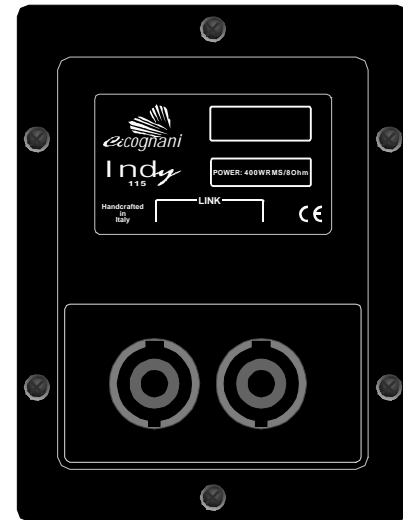

Le prese SPEAKON sono collegate in parallelo; una presa può essere utilizzata per il collegamento della cassa all'uscita di un amplificatore di potenza, l'altra per collegare un secondo box.

The SPEAKON sockets are wired in parallel mode; one socket can be used to connect the loudspeaker to the output of a power amplifier, while the other can be used to connect a second loudspeaker.

Les prises SPEAKON sont branchées en parallèle; une prise peut être utilisée pour le branchement de l'enceinte à la sortie d'un amplificateur de puissance, l'autre pour brancher un second boîtier.

Die SPEAKON -Buchsen sind parallel geschaltet; eine Buchse kann zum Anschluss der Box an den Ausgang eines Leistungsverstärkers, die andere zum Anschluss einer zweiten Box verwendet werden.

Indy

210

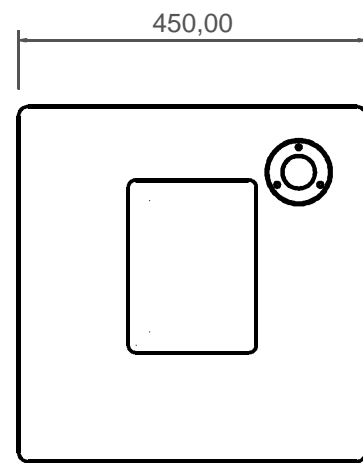
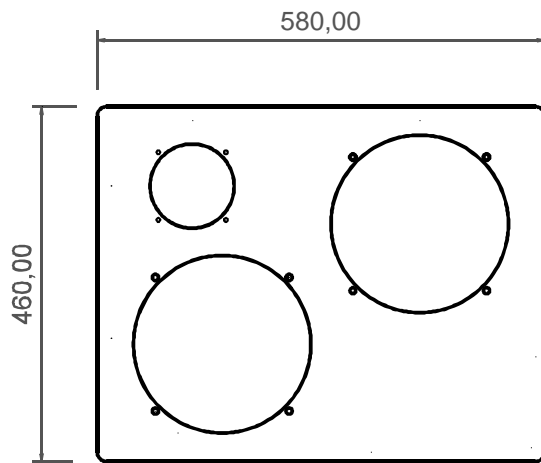

Indy

115

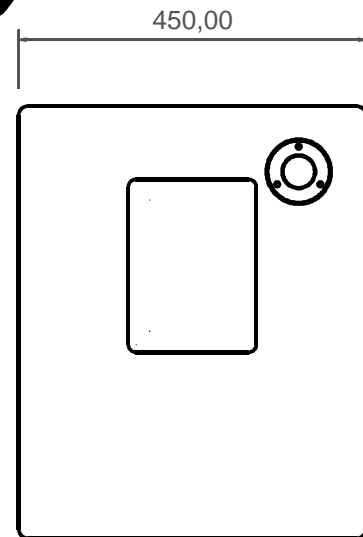
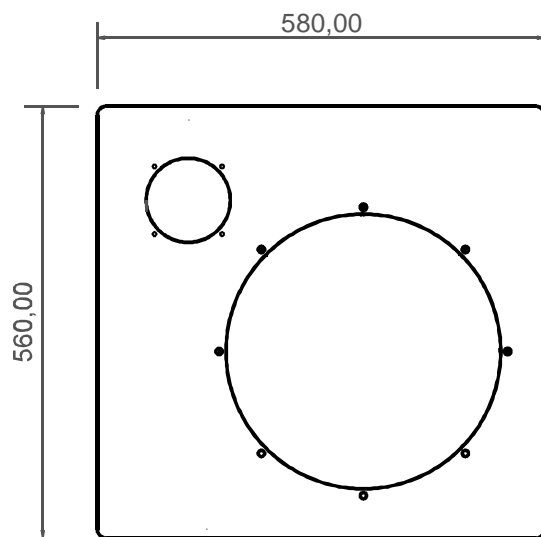

code 29204



La **FBT ELETTRONICA SpA** si riserva il diritto di modificare le caratteristiche tecniche ed estetiche dei prodotti in qualsiasi momento e senza preavviso. Questo prodotto osserva i requisiti delle Direttive Europee 89/336EEC

FBT ELETTRONICA SpA reserves the right to change the technical and visual features of the products in any moment without notice. This product is pursuant to European Directives 89/336EEC

FBT Elettronica S.P.A. se réserve le droit de pouvoir modifier les caractéristiques techniques et l'aspect extérieur des produits, à tout moment et sans préavis. Ce produit est conforme aux directives européennes 89/336EEC.

Die FBT ELETTRONICA Spa behält sich das Recht vor, technische und gestalterische Einzelheiten der Produkte jederzeit und ohne Ankündigung zu ändern. Dieses Produkt erfüllt die Vorgaben der Europäischen Richtlinie 89/336EEC.